

# PASTA MONTAGGIO PNEUMATICI

PASTE TO MOUNT TYRES

PÂTE POUR LE MONTAGE DES PNEUS



3080005IT



3080005SIT



3080005NIT

















3080006IT

## Pasta montaggio pneumatici moto / vettura

Tyre mounting paste for motorbike / cars

Pâte de montage pneus moto / tourism

Code Code Code	Descrizione Description Description	Note Notes Notes	Peso kg Weight kg Poids kg	Applicazione Application Application
3080004	Pasta montaggio pneumatici moto / vettura - STANDARD SLIP WHITE Tyre mounting paste for motorbike / cars - STANDARD SLIP WHITE Pâte de montage pneus tourism - STANDARD SLIP WHITE	Bianca White Blanche	1	 
3080005	Pasta montaggio pneumatici moto / vettura - STANDARD SLIP WHITE Tyre mounting paste for motorbike / cars - STANDARD SLIP WHITE Pâte de montage pneus tourism - STANDARD SLIP WHITE	Bianca White Blanche	4	 
3080005IT	Pasta montaggio pneumatici moto / vettura - STANDARD SLIP WHITE Tyre mounting paste for motorbike / cars - STANDARD SLIP WHITE Pâte de montage pneus tourism - STANDARD SLIP WHITE	Bianca White Blanche	5	 
3080005NIT	Pasta montaggio pneumatici moto / vettura - EXTRA SLIP BLACK Tyre mounting paste for motorbike / cars - EXTRA SLIP BLACK Pâte de montage pneus tourism - EXTRA SLIP BLACK	Nera Black Noire	5	  
3080005SIT	Pasta montaggio pneumatici moto / vettura - EXTRA SLIP BLUE Tyre mounting paste for motorbike / cars - EXTRA SLIP BLUE Pâte de montage pneus tourism - EXTRA SLIP BLUE	Azzurra Light Blue Azur	5	  
3080005TR	Pasta montaggio pneumatici moto / vettura - EXTRA SLIP GHOST Tyre mounting paste for motorbike / cars - EXTRA SLIP GHOST Pâte de montage pneus tourism - EXTRA SLIP GHOST	Trasparente Transparent Transparent	5	  

**PASTA MONTAGGIO PNEUMATICI**  
**PASTE TO MOUNT TYRES**  
**PÂTE POUR LE MONTAGE DES PNEUS**



308006IT



308006PLUS



3080007



3080007IT

**Pasta montaggio pneumatici camion**  
**Tyre mounting paste truck**  
**Pâte de montage pneus camion**

Codice Code Code	Descrizione Description Description	Note Notes Notes	Peso kg Weight kg Poids kg	Applicazione Application Application
3080006	Grasso di montaggio pneumatici camion - TRUCK GREASE YELLOW <i>Tyre mounting grease for truck - TRUCK GREASE YELLOW</i> <i>Graisse de montage pneus camion - TRUCK GREASE YELLOW</i>	Gialla Yellow Jaune	4	
3080006IT	Grasso di montaggio pneumatici camion - TRUCK GREASE YELLOW <i>Tyre mounting grease for truck - TRUCK GREASE YELLOW</i> <i>Graisse de montage pneus camion - TRUCK GREASE YELLOW</i>	Gialla Yellow Jaune	5	
3080006PLUS	Grasso speciale di montaggio pneumatici camion - TRUCK GREASE GOLD+ <i>Special Tyre mounting grease for truck - TRUCK GREASE GOLD+</i> <i>Graisse spécial de montage pneus camion - TRUCK GREASE GOLD+</i>	Oro Gold Or	5	
3080007IT	Grasso LINCE Italmatic - TRUCK LINX GREASE (comparabile a TIGRE Michelin) <i>LINX grease Italmatic - TRUCK LINX GREASE (comparable with TIGRE Michelin)</i> <i>Graisse LINX Italmatic - TRUCK LINX GREASE (comparable avec TIGRE Michelin)</i>	Oro Gold Or	4	
3080007	Grasso TIGRE 80 Michelin <i>TIGRE 80 Grease Michelin</i> <i>Graisse TIGRE 80 Michelin</i>	Oro Gold Or	4	



# PASTA MONTAGGIO PNEUMATICI

## PASTE TO MOUNT TYRES

## PÂTE POUR LE MONTAGE DES PNEUS



3080008C



3080005D



3080008A



3080005B



3080005A



3080008B

### Lubrificanti montaggio / smontaggio Mounting / demounting lubricators Monte / demonte lubrifiants

Codice Code Code	Descrizione Description Description	Note Notes Notes	Contenuto Content Contenu
3080005A	Fluido Italmatic spray trasparente per montaggio Transparent spray Italmatic fluid for assembling Fluide Italmatic vaporisateur transparent pour montage	Spray	400 ml
3080005B	Fluido Italmatic spray blu trasparente per smontaggio Transparent blue spray Italmatic fluid for disassembling Fluide Italmatic vaporisateur transparent bleu pour démontage	Spray	400 ml
3080005D	Pasta spray Socolub montaggio pneumatici moto/auto Spray paste Socolub to mount motorcycle/car tyres Pâte spray Socolub pour le montage de pneus motorcycle/tourisme	Spray	400 ml
3080008A	Fluido Italmatic trasparente per montaggio Transparent Italmatic fluid for assembling Fluide Italmatic transparent pour montage	Liquido Liquid Liquide	5 lt
3080008B	Fluido Italmatic blu trasparente per smontaggio Transparent blue Italmatic fluid for disassembling Fluide Italmatic transparent bleu pour démontage	Liquido Liquid Liquide	5 lt
3080008C	Super lubrificante liquido per montaggio Patch Rubber (46-250) (si può diluire in acqua o usare concentrato) - per tutti gli pneumatici Patch Rubber liquid super lubricator for mounting (46-250) (it can be diluted into water or used concentrated) - for all types of tyres Super lubrifiant liquide pour montage Patch Rubber (46-250) (il peut être dilué dans l'eau ou utilisé concentré) - pour tous les pneus	Trasparente Transparent Transparent	4 kg



3070170IT



3070150



3080010



3080009



3080009A



3080009B



3080009C

**Sigillanti per talloni e pennelli**  
**Bead sealers and Brushes**  
**Solutions pour talons et Brosses**

Codice Code Code	Descrizione Description Description	Contenuto Content Contenu
3070150	Sigillante per talloni da 1 lt <i>Bead sealer (1 lt)</i> <i>Solution adhésive pour talons (1 lt)</i>	1 LT
3070170IT	Sigillante per talloni ITALMATIC BEAD SEALER <i>ITALMATIC BEAD SEALER</i> <i>Solution pour talons ITALMATIC REPAIR SEALER</i>	1 LT
3080010	Talco per montaggio di pneumatici con camera d'aria <i>Talc to mount tyres with air tubes</i> <i>Talc pour montage de pneus avec chambre à air</i>	0,5 kg
3080009	Pennello ø 30 per pasta e grasso in plastica <i>Plastic brush ø 30 for paste and grease</i> <i>Pinceau en plastique ø 30 pour pâte et graisse</i>	—
3080009A	Pennello ø 30 per pasta e grasso in legno <i>Wood brush ø 30 for paste and grease</i> <i>Pinceau en bois ø 30 pour pâte et graisse</i>	—
3080009B	Pennello in legno ricurvo per pasta e grasso <i>Bent wooden brush for paste and grease</i> <i>Pinceau en bois recourbé pour pâte et graisse</i>	—
3080009C	Tampone per applicazione lubrificante liquido montaggio 3080008C <i>Pad to apply the liquid lubricator for mounting 3080008C</i> <i>Tampon pour application lubrifiant liquide montage 3080008C</i>	—



**RAIDEX**



3080019R



3080019V



3080019S



3080019B



3080019G



**Gessi Sisa  
Sisa chalks  
Craies Sisa**

Codice Code Code	Descrizione Description Description	Colore	Lunghezza cm Length in cm Longueur en cm	Ø mm Ø mm Ø mm	Pz. / scatola Pcs. / box Pcs. / boîte
3080019B	Gessi SISA Sisa chalks Craies Sisa	Bianchi White Blanche	9	17,5	12
3080019G	Gessi SISA Sisa chalks Craies Sisa	Gialli yellow jaunes	9	17,5	12
3080019R	Gessi Sisa Sisa Chalks Craies Sisa	Rosso Red Rouge	9	17,5	12
3080019S	Gessi Sisa Sisa Chalks Craies Sisa	Rosa Pink Rose	9	17,5	12
3080019V	Gessi Sisa Sisa Chalks Craies Sisa	Verde Green Verte	9	17,5	12
3080019H	Porta gessi Chalks holder Porte Caraie	-	-	17,5	1



3080019H



**Gessi Italmatic alte prestazioni  
Italmatic chalks high performances  
Craies Italmatic high performances**

Code Code Code	Descrizione Description Description	Colore	Lunghezza cm Length in cm Longueur en cm	Ø mm Ø mm Ø mm	Pz. / scatola Pcs. / box Pcs. / boîte
3080019B-IT	Gessi Italmatic Italmatic chalks Craies Italmatic	Bianchi White Blanche	9	17,5	12
3080019G-IT	Gessi Italmatic Italmatic chalks Craies Italmatic	Gialli yellow jaunes	9	17,5	12
3080019S-IT	Gessi Italmatic Italmatic Chalks Craies Italmatic	Rosa Pink Rose	9	17,5	12
3080020-IT	Gessi Italmatic Italmatic chalks Craies Italmatic	Bianchi White Blanche	12	12,5	12
3080021G-IT	Gessi Italmatic Italmatic chalks Craies Italmatic	Gialli yellow jaunes	12	12,5	12
3080021S-IT	Gessi Italmatic Italmatic Chalks Craies Italmatic	Rosa Pink Rose	12	12,5	12
3080018-IT	Porta gessi Chalks holder Porte Craie	-	-	17,5	-
3080018S-IT	Porta gessi Chalks holder Porte Craie	-	-	12,5	-



**LEVE**  
**LEVERS**  
**LEVIERS**



**Leve per pneumatici vettura**  
**Levers for car tyres**  
**Leviers pour pneus tourisme**

Codice Code Code	Descrizione Description Description	Lunghezza pollici Length in inches Longueur en pouces	Lunghezza mm Length in mm Longueur en mm
3030035	Leva originale Moto - Michelin Original Moto lever - Michelin Levier original Moto - Michelin	15	380
3030035B	Leva corta e piatta speciale per moto e bicicletta Special short and flat lever for motorcycle and bike Levier court et plat spécial pour motocycle et vélo	8	200
3030035C	Leva corta e piatta speciale per moto e bicicletta Special short and flat lever for motorcycle and bike Levier court et plat spécial pour motocycle et vélo	9,5	240
3030036	Leva originale Dowidat Original Dowidat lever / Levier original Dowidat	8	200
3030037	Leva originale Dowidat Original Dowidat lever / Levier original Dowidat	12	300
3030038	Leva originale Dowidat Original Dowidat lever / Levier original Dowidat	16	400
3030039	Leva originale Dowidat Original Dowidat lever / Levier original Dowidat	20	500
3030040	Leva originale Dowidat Original Dowidat lever / Levier original Dowidat	24	600
3030041A	Leva originale FUSIL - Michelin FUSIL Michelin original lever Levier original FUSIL Michelin	15	380



3030043



3030044



3030043P



3030044K

**Leve per pneumatici vettura**  
**Levers for car tyres**  
**Leviers pour pneus tourisme**

Codice Code Code	Descrizione Description Description	Lunghezza pollici Length in inches Longueur en pouces	Lunghezza mm Length in mm Longueur en mm
3030042	Leva normale Normal lever Levier normal	16	400
3030043	Leva normale Normal lever Levier normal	20	500
3030043B	Leva normale con estremità a doppia curva Normal lever with double curve end Levier normal avec extrémité à double courbe	20	500
3030043P	Leva normale con protezione in ABS incorporata Normal lever with incorporated ABS protection Levier normal avec protection en ABS incorporé	20	500
3030043PR	Protezione ABS di ricambio per leva 3030043P Spare ABS protection for lever 3030043P Protection ABS de rechange pour levier 3030043P	-	-
3030043Q	Leva con effetto gancio con protezione incorporata Tyre lever with hook effect, with incorporated protection Levier avec ""hook effect"", avec protection incorporé	20	500
3030044	Leva speciale per Run Flat Special lever for Run Flat / Levier spécial pour Run Flat	20	500
3030044K	Utensile speciale per smontaggio senza sforzo di gomme basso profilo Special tool for dismantling without effort low profile tyres Outil spécial pour démonter sans effor pneus profil bas	-	-





**LEVE**  
**LEVERS**  
**LEVIERS**

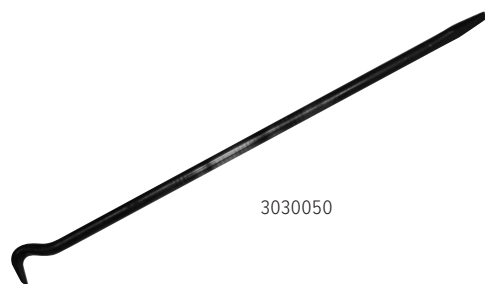

3030050



3030051

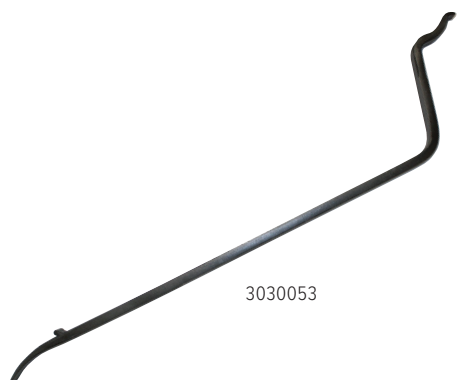

3030053

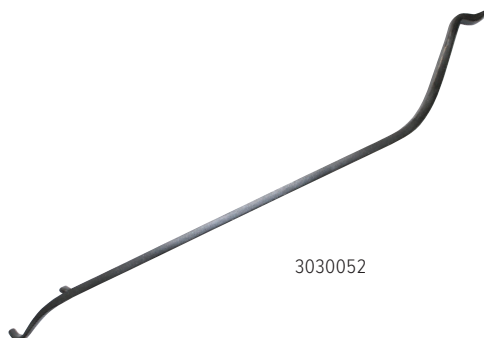

3030052

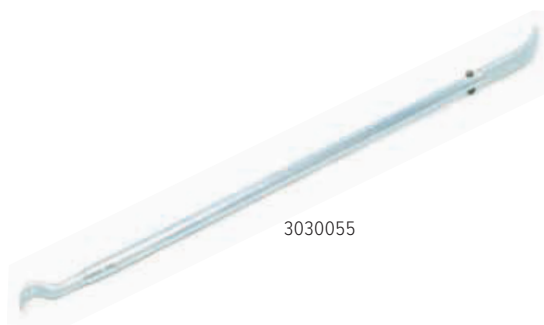

3030055



3030058

**Leve per pneumatici autocarro e M.T.**  
**Levers for truck tyres and E.M.**  
**Leviers pour pneus camion et G.C.**

Codice Code Code	Descrizione Description Description	Lunghezza pollici Length in inches Longueur en pouces	Lunghezza mm Length in mm Longueur en mm
3030050	Leva per cerchietti / <i>Lever for small rims / Levier pour petites jantes</i>	26	670
3030051	Leva tipo Sayam; ideale per Movimento Terra <i>Lever similar to Sayam; ideal for E.M. / Levier similaire à Sayam; idéal pour G.C.</i>	36	920
3030052	Leva tipo Hyude / <i>Lever similar to Hyude / Levier similaire à Hyude</i>	39	990
3030053	Leva tipo Hyoca / <i>Lever similar to Hyoca / Levier similaire à Hyoca</i>	36	920
3030055	Leva Trilex gigante / <i>Large Trilex lever / Levier Trilex grand</i>	55	1400
3030056	Punta di ricambio per leva Trilex <i>Spare pin for Trilex lever / Pointe de rechange pour levier Trilex</i>	–	–
3030057	Punta di ricambio saldata per leva Trilex <i>Spare welded pin for Trilex lever / Pointe de rechange soudée pour levier Trilex</i>	–	–
3030058	Leva per autocarro con uncino <i>Tubeless truck tyre lever with hook / Levier avec le crochet pour jantes tubeless camion</i>	27	675



3030060A



3030060D



3030060B



3030060C



3030060E



3030070

**Leve per pneumatici autocarro e M.T.  
Levers for truck tyres and E.M.  
Leviers pour pneus camion et G.C.**

Codice Code Code	Descrizione Description Description	Lunghezza pollici Length in inches Longueur en pouces	Lunghezza mm Length in mm Longueur en mm
3030060A	Leva di montaggio tubeless camion & bus / Mounting lever for tubeless truck & bus tire / Levier de montage pneus tubeless camion & bus	41	1050
3030060B	Leva di smontaggio tubeless camion/bus / Demounting lever for tubeless truck/bus tire. Levier de démontage pneus tubeless camion/bus	70	1780
3030060C	Leva di montaggio tubeless cerchi lega camion/bus / Mounting lever for tubeless truck/bus tire alloy rims / Levier de montage pneus tubeless camion/bus jantes alliage	41	1040
3030060D	Leva di smontaggio tubeless cerchi lega camion/bus / Demounting lever for tubeless truck/bus tire alloy rims / Levier de démontage pneus tubeless camion/bus jantes alliage	63	1610
3030060E	Stallonatore estensibile Extensible impact bead breaker / Détallonneur extensible	50-80	1270-2030
3030070	Sbloccatallonati tipo Fagus / Beads unlocking tool similar to Fagus Dispositif de déblocage des talons similaire à Fagus	39	1000

CONTRAPRESSI PER INCAICCIATURA  
BALANCING WEIGHTS  
VALVOLE E PROLUNGHE  
VALVES AND EXTENSIONS  
CONFECCIO  
WRAPPING  
CONFECCIO E ACCESSORI  
TIRE MOUNTING AND DEMOUNTING  
AIR COMPRESSOR  
COMPRESSED AIR  
PRODOTTORE PNEUMATICO  
TYRE REPAIRING  
SOLLEVAMENTO E ACCESSORI  
LIFTING AND ACCESSORIES  
SOLLEVAMENTO E ACCESSORI  
TYRE CARE AND MAINTENANCE  
ATTREZZATURE E ACCESSORI  
TYRE EQUIPMENTS AND ACCESSORIES  
TPMS  
TPMS

**LEVE**  
**LEVERS**  
**LEVIERS**



3030062



3030064



3030068

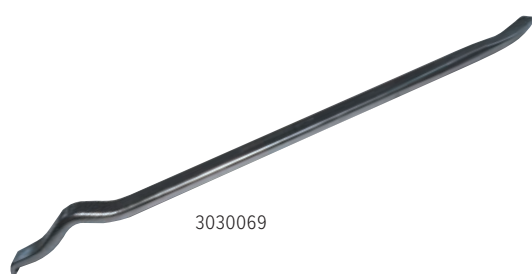

3030069

**Leve per pneumatici autocarro e M.T.**  
**Levers for truck tyres and E.M.**  
**Leviers pour pneus camion et G.C.**

Codice Code Code	Descrizione Description Description	Lunghezza pollici Length in inches Longueur en pouces	Lunghezza mm Length in mm Longueur en mm
3030062	Leva originale Halte Original Halte lever Lever original Halte - Michelin	31,5	800
3030063	Leva tipo Halte Lever similar to Halte Lever similaire à Halte	31,5	800
3030064	Leva originale Face Original Face lever Lever original Face - Michelin	20,5	520
3030065	Leva tipo Face Lever similar to Face Lever similaire à Face	20,5	520
3030068	Leva originale Force Force original lever Lever original Force - Michelin	29,5	750
3030069	Leva montaggio autocarro in acciaio cromato Truck mounting lever in chromed steel Lever pour montage camion en acier chromé	24	610



3030045A



3030045D



3030045AP



3030048Z



3030046



3030045



3030049A



3030049

**Protezioni e leve speciali**  
**Protections and special levers**  
**Protections et leviers speciaux**

Code Code Code	Descrizione Description Description	Lunghezza pollici Length in inches Longueur en pouces	Lunghezza mm Length in mm Longueur en mm
3030045	Protezione in plastica per cerchi in lega per leva cod. 3030043 <i>Plastic protection for alloy rims for lever code 3030043</i> <i>Protection en plastique pour jantes en alliage pour levier code 3030043</i>	-	-
3030045A	Protezione in plastica per cerchi in lega <i>Plastic protection for alloy rims</i> <i>Protection en plastique pour jantes en alliage</i>	-	-
3030045AP	Protezione in Poliuretano per cerchi in lega <i>Polyurethane protection for alloy rims</i> <i>Protection en polyuréthane pour jantes en alliage</i>	-	-
3030045D	Protezione in plastica corta <i>Short plastic protection / Protection en plastique courte</i>	-	-
3030046	Utensile premitallone <i>Bead hold-down device / Aide démonte-pneu</i>	12	300
3030048Z	Leva speciale per smontaggio copricerchi <i>Special lever to demount rim covers</i> <i>Levier spécial pour démonter les couvre-jantes</i>	-	-
3030049	Leva speciale per smontaggio copricerchi <i>Special lever to demount rim covers</i> <i>Levier spécial pour démonter les couvre-jantes</i>	13,8	350
3030049A	Leva per raddrizzare cerchi deformati <i>Lever for straightening deformation on rim flange</i> <i>Levier pour redresser les jantes déformées</i>	15,5	390

## STRUMENTI DI MONTAGGIO

### MOUNTING TOOLS

### ACCESSOIRES POUR MONTAGE



3030070A



3030070B



3030070E



3030070F



3030070G



3030070L



3030070M



3030070N



3030070P



3030070R

### Accessori per montaggio e smontaggio

### Accessories for mounting and demounting / Accessoires pour montage et démontage

Codice Code Code	Descrizione Description Description	Lunghezza pollici Length in inches Longueur en pouces	Lunghezza mm Length in mm Longueur en mm
3030070A	Attrezzo stallonatore con manico con protezione di plastica <i>Tyre remover tool with plastic protection handle</i> <i>Dispositif détalonneur avec protection en plastique sur la poignée</i>	13	330
3030070B	Attrezzo stallonatore <i>Tyre remover / Dispositif détalonneur</i>	12	300
3030070E	Blocco talloni autocarro <i>Truck tyre bead holder / Coince-talon pour pneus camion</i>	–	–
3030070F	Blocco talloni autocarro in metallo <i>Metal truck tyre bead holder</i> <i>Coince-talon en métal pour pneus camion</i>	–	–
3030070L	Strumento di montaggio per pneumatici camion <i>System for mounting truck tyres / Système pour le montage des pneus camion</i>	–	–
3030070P	Strumento di montaggio per pneumatici basso profilo <i>Mounting tool for low profile tyres / Outil de montage pour pneus à profil bas</i>	–	–
3030070G	Blocca talloni in metallo leggero per autocarro <i>Light metal truck tyre bead holder / Coince-talon en métal léger pour pneus camion</i>	–	–
3030070M	Strumento di montaggio per pneumatici camion <i>Tool for mounting truck tyre / Outil pour le montage des pneus camion</i>	–	–
3030070N	Strumento di montaggio per pneumatici camion <i>Tool for mounting truck tyre / Outil pour le montage des pneus camion</i>	–	–
3030070R	Strumento di montaggio per pneumatici basso profilo <i>Mounting tool for low profile tyres / Outil de montage pour pneus à profil bas</i>	–	–



**Chiave a croce universale**  
**Universal cross wrench / Clef en forme de croix universelle**

Codice Code Code	Descrizione Description Description	Misure Sizes Dimensions
3030071	Chiave croce vettura Car cross wrench Clef en forme de croix tourisme	17-19-21-22
3030071Q	Chiave croce vettura con attacco quadro Car cross wrench with square connector Clef en forme de croix tourisme avec connecteur carré	17-19-22-1/2"
3030071R	Chiave croce vettura rinforzata Reinforced car cross wrench Clef en forme de croix tourisme renforcée	17-19-21-22
3030072	Chiave croce autocarro professionale Professional truck cross wrench Clef en forme de croix professionnelle pour camion	24-27-32-3/4"
3030073	Chiave estendibile Extensible wrench Clef extensible	17-19-21-23
3030074	Kit moltiplicatore di forza 1:56 ideale per allentare / stringere bulloni autocarro. Composto da manovella, estensione bussola 32 e 33 mm Force multiplier kit 1:56 ideal to loosen / tighten truck nuts. Consisting of handle, extension, impact sockets 32 and 33 mm Kit multiplicateur de force 1:56 idéal pour desserrer / serrer les boulons camion. Composé par poignée, rallonge, douilles 32 et 33 mm	32-33

CONTRAPESSE PER LANCIA  
 BALANCING WEIGHTS  
 VALVOLE E PIGNONE  
 VALVES AND EXTENSIONS  
 COPERTURE  
 COVERS  
 MONTAGGIO E ACCESSORI  
 THE MOUNTING AND ACCESSORIES  
 OIL COMPRESSOR  
 COMPRESSED AIR  
 PNEUMATICO NEUMATICO  
 TIRE REPAIRING  
 SOLLEVAMENTO E ACCESSORI  
 LIFTING AND ACCESSORIES  
 CURA E MANUTENZIONE  
 TIRE CARE AND MAINTENANCE  
 ATTREZZI E ACCESSORI  
 OTHER EQUIPMENTS AND ACCESSORIES  
 TPMS  
 TPMS

**ANELLI MONTAGGIO E OR**  
**MOUNTING RINGS AND OR**  
**ANNEAUX DE MONTAGE ET OR**



3070163



3070168



3070169

**Anelli di montaggio per tubeless**  
**Mounting rings for tubeless**  
**Anneaux de montage pour tubeless**

Codice Code Code	Descrizione Description Description	Misura in Pollici Size in inches Dimension en pouces	Ø corda mm Ø cord mm Ø corde mm	Tipo Type Type
3070160	Anello montaggio tubeless PC 1 Mounting ring for tubeless PC 1 Anneau de montage pour tubeless PC 1	13" / 14"	45	–
3070161	Anello montaggio tubeless PC 2 Mounting ring for tubeless PC 2 Anneau de montage pour tubeless PC 2	14" / 15"	50	–
3070163	Anello montaggio tubeless Mounting ring for tubeless Anneau de montage pour tubeless	16,5" / 17,5"	30	–
3070164	Anello montaggio tubeless Mounting ring for tubeless Anneau de montage pour tubeless	19,5"	30	–
3070165	Anello montaggio tubeless Mounting ring for tubeless Anneau de montage pour tubeless	22,5" / 24,5"	30	–

**Guarnizioni O-Ring**  
**O-Ring rings**  
**Anneau O-Ring**

Codice Code Code	Descrizione Description Description	Misura in Pollici Size in inches Dimension en pouces	Ø corda mm Ø cord mm Ø corde mm	Tipo Type Type
3070166	Anello OR 220T-TG OR ring 220T-TG / Anneau OR 220T-TG	20"	6	–
3070167	Anello OR 224T-TG OR ring 224T-TG / Anneau OR 224T-TG	24"	6	–
3070168	Anello OR 25T OR ring 25T / Anneau OR 25T	25"	6	Huepo
3070169	Anello OR 325T OR ring 325T / Anneau OR 325T	25"	9	Sulla
3070170	Anello OR 333T OR ring 333T / Anneau OR 333T	33"	9	Strix

N.B. Altre misure disponibili su richiesta  
 Other sizes available on request  
 D'autres dimensions sont disponibles sur demande



3070180-3070187

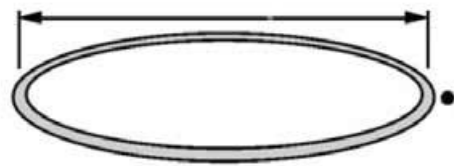
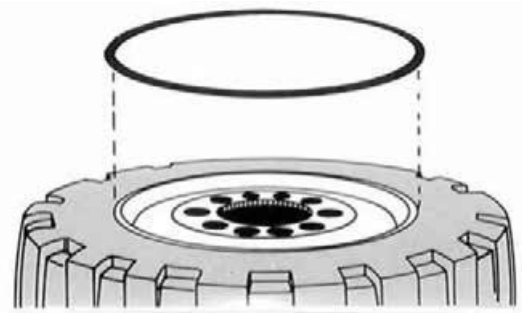

**Anelli di montaggio OR senza giuntura**  
**Endless OR mounting rings**  
**Anneaux de montage OR sans jonction**

Codice Code Code	Descrizione Description Description	Misura in Pollici Size in inches Dimension en pouces	Ø corda mm Ø cord mm Ø corde mm	Tipo Type Type
3070180	Anello OR 25T senza giunture 25T endless OR mounting ring Anneau de montage OR 25T sans jonction	25"	6	Huepo
3070181	Anello OR 325T senza giunture 325T endless OR mounting ring Anneau de montage OR 325T sans jonction	25"	9	Sulla
3070182	Anello OR 329T senza giunture 329T endless OR mounting ring Anneau de montage OR 329T sans jonction	29"	9	Sulky
3070183	Anello OR 333T senza giunture 333T endless OR mounting ring Anneau de montage OR 333T sans jonction	33"	9	Strix
3070184	Anello OR 335T senza giunture 335T endless OR mounting ring Anneau de montage OR 335T sans jonction	35"	9	Stras
3070185	Anello OR 349T senza giunture 349T endless OR mounting ring Anneau de montage OR 349T sans jonction	49"	9	Heyco
3070186	Anello OR 451T senza giunture 451T endless OR mounting ring Anneau de montage OR 451T sans jonction	51"	9	-
3070187	Anello OR 457T senza giunture 457T endless OR mounting ring Anneau de montage OR 457T sans jonction	57"	9	-

**Anelli tipo "L"**  
**"L" Type rings - Joints type "L"**

Codice Code Code	Descrizione Description Description	Misura in Pollici Size in inches Dimension en pouces
3070188	Anello di gonfiaggio tipo "L" LR20 "L" type ring LR20 / Joints type "L" LR20	20"
3070188B	Anello di gonfiaggio tipo "L" LR25 "L" type ring LR25 / Joints type "L" LR25	25"
3070188C	Anello di gonfiaggio tipo "L" LR29 "L" type ring LR29 / Joints type "L" LR29	29"
3070188D	Anello di gonfiaggio tipo "L" LR33 "L" type ring LR33 / Joints type "L" LR33	33"

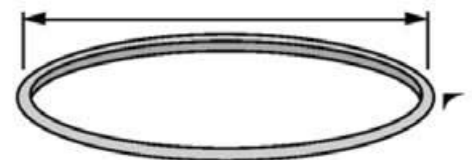



**ANELLI MONTAGGIO E OR**  
**MOUNTING RINGS AND OR**  
**ANNEAUX DE MONTAGE ET OR**

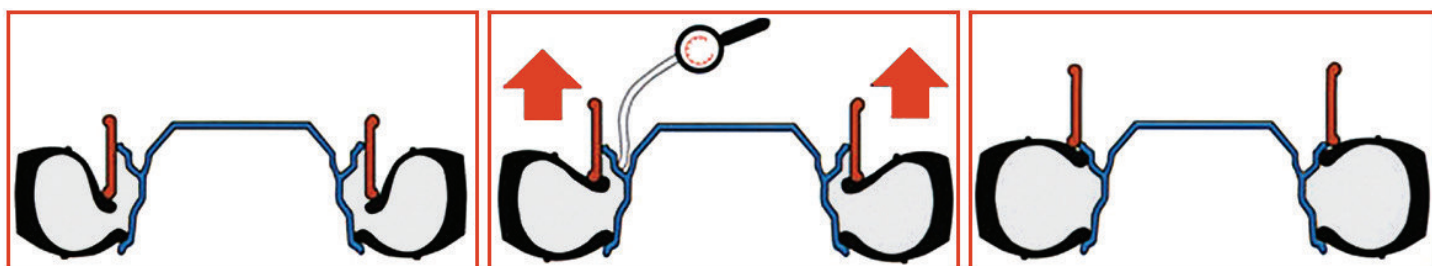

**Fasce rigide di gonfiaggio**  
**Rigid pump ring**  
**Anneau de gonflage rigid**



Codice Code Code	Descrizione Description Description	Misura in Pollici Size in inches Dimension en pouces
3070193A	Anello di gonfiaggio Inflating ring / Anneau de gonflage	13"
3070193B	Anello di gonfiaggio Inflating ring / Anneau de gonflage	14"
3070193C	Anello di gonfiaggio Inflating ring / Anneau de gonflage	15"
3070193D	Anello di gonfiaggio Inflating ring / Anneau de gonflage	16"
3070193G	Anello di gonfiaggio Inflating ring / Anneau de gonflage	17,5"
3070193H	Anello di gonfiaggio Inflating ring / Anneau de gonflage	19,5"
3070193J	Anello di gonfiaggio Inflating ring / Anneau de gonflage	20"
3070193K	Anello di gonfiaggio Inflating ring / Anneau de gonflage	22,5"
3070193L	Anello di gonfiaggio Inflating ring / Anneau de gonflage	24"

**Anelli di gonfiaggio flessibili**  
**Inflating flexible rings**  
**Anneaux de gonflage souples**

Codice Code Code	Descrizione Description Description	Misura in Pollici Size in inches Dimension en pouces
3070193AR	Anelli di gonfiaggio flessibili Inflating flexible rings / Anneaux de gonflage souples	13"
3070193BR	Anelli di gonfiaggio flessibili Inflating flexible rings / Anneaux de gonflage souples	14"
3070193CR	Anelli di gonfiaggio flessibili Inflating flexible rings / Anneaux de gonflage souples	15"
3070193DR	Anelli di gonfiaggio flessibili Inflating flexible rings / Anneaux de gonflage souples	16"
3070193ER	Anelli di gonfiaggio flessibili Inflating flexible rings / Anneaux de gonflage souples	17,5"
3070193FR	Anelli di gonfiaggio flessibili Inflating flexible rings / Anneaux de gonflage souples	16,5"
3070193HR	Anelli di gonfiaggio flessibili Inflating flexible rings / Anneaux de gonflage souples	19,5"
3070193KR	Anelli di gonfiaggio flessibili Inflating flexible rings / Anneaux de gonflage souples	22,5"





**Smonta gomme manuali**  
**Tyre changer - Démonte pneus**

Code Code Code	Descrizione Description Description
3080116	Smonta gomme manuale "All-in-One" per pneumatici fino 22". Consente di cambiare pneumatici senza bisogno di aria compressa ed elettricità. Completo di adattatori ed accessori Manual tyre changer "All-in-One" for tyres up to 22". It allows to change tyres without need of electricity or compressed air. Complete with adaptors and accessories Démonte pneus manuel "All-in-One" pour pneus jusqu'à 22 ». Il permet de changer les pneus sans besoin d'air comprimé et électricité. Complet d'adaptateurs et accessoires
3080116D	Smontagomme manuale economico per pneumatici vettura fino a 16,5" Manual tyre changer for tyres up to 16,5" Démonte pneus manuel économique pour pneus jusqu'à 16,5"
3080116E	Supporto per 3080116D completo di stallonatore manuale Stand for 3080116D including manual beadbreaker Support pour 3080116D dé talonneurs manuel
3080116F	Piattaforma di fissaggio a pavimento per 3080116E Floor plate for 3080116E Plaque de sol pour 3080116E



CONTRAPESO PER IL MANICOTTO  
BALANCING WEIGHT  
VALVOLA PER PNEUMICHE  
VALVES AND EXHAUSTS  
CONFESSIONI  
INSTALLING  
CONFESSIONI  
INSTALLING AND OILING  
OIL, COMPRESSA  
COMPRESSED AIR  
OPERAZIONE PNEUMATICA  
TYRE REPAIRING  
SOLLEVAMENTO E ACCESSORI  
LIFTING AND ACCESSORIES  
CURE E MANUTENZIONE  
TYRE CARE AND MAINTENANCE  
ATTREZZATURE E ACCESSORI  
OTHER EQUIPMENTS AND ACCESSORIES  
TPMS  
TPMS

# INTALLONATORI

## BEAD SEATERS

## BEAD SEATERS

3080079A



3080079D

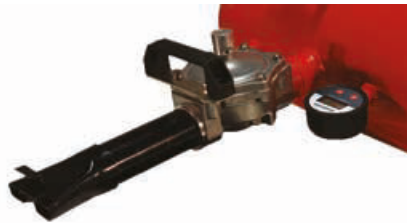

3080080



### Intallonatori Bead seaters Bead seaters

Codice Code Code	Descrizione Description Description
3080079A	Intallatore manuale con manometro analogico, 19lt, 12kg Manual bead seater 12kg, 19lt, with analogic gauge Bead seater manuel 12kg, 19lt, manomètre analogique
3080079D	Intallatore automatico in alluminio ultraleggero, manometro digitale, 19lt, 6kg Automatic aluminium bead seater light weight, 19lt, 6kg Bead seater automatique 6kg, 19lt, manomètre digital
3080080	Intallatore manuale lt 20, peso 13 kg Manual system lt 20, weight 13 kg Système manuel lt 20, poids 13 kg
3080080A	Sistema manuale lt 38, per M.T. Manual system lt 38, for E.M. Système manuel lt 38, pour G.C.
3080080B	Bead Booster Bazooka 6lt Bazooka bead booster 6lt Bead booster Bazooka 6lt
3080080C	Bead Booster Bazooka 9lt per pneumatici camion Bazooka bead booster 9lt for truck tyres Bead booster Bazooka 9lt pour pneus camion
3080080D	Bead Booster Bazooka 12lt per pneumatici camion Bead Booster Bazooka 12lt for truck tyres Bead Booster Bazooka 12lt pour pneus camion



3080080B/C/D



3080080A



3080081

3080080BN



3080080CN



3080080DN



3080082K1



3080082K2

**Intallonatori 2.0**  
**Bead seaters 2.0**  
**Bead seaters 2.0**

Codice Code Code	Descrizione Description Description
3080081	Intallonatore manuale con valvola RAR (rilascio rapido) 20L Manual bead seater with valve RAR (quick release) 20L Bead seater manuel avec valve RAR (libération rapide) 20L
3080082K1	Upgrade kit 1 per trasformare il 3080080 in 3080081 Upgrade kit 1 to transform 3080080 into 3080081 Upgrade kit 1 pour transformer 3080080 en 3080081
3080082K2	Upgrade kit 2 per trasformare il 3080080 in 3080081 Upgrade kit 2 to transform 3080080 into 3080081 Upgrade kit 2 pour transformer 3080080 en 3080081
3080080BN	Bead Booster Bazooka 3lt (gen2) Bead Booster Bazooka 3lt (gen2) Bead Booster Bazooka 3lt (gen2)
3080080CN	Bead Booster Bazooka 6lt (gen2) Bead Booster Bazooka 3lt (gen2) Bead Booster Bazooka 3lt (gen2)
3080080DN	Bead Booster Bazooka 10lt (gen2) Bead Booster Bazooka 3lt (gen2) Bead Booster Bazooka 3lt (gen2)
3080080RK	Kit manutezione Bazooka Gen 2 Maintenance kit Bazooka Gen 2 Kit entretien Bazooka Gen 2



3080080RK



# STALLONATORI BEAD BREAKERS DÉTALONNEURS



3080085



3080085G



3080085C



3080085L



## Stallonatori idraulici portatili Portable hydraulic bead breakers Détalonneurs portables hydrauliques

Codice Code Code	Descrizione Description Description	Note Notes Notes	Peso kg Weight kg Poids kg
3080085	MICRO-LEM	Adatto per stallonare i pneumatici di tutti i tipi di jeep, fuoristrada, vetture, camion senza bordo anti stallonamento e trattori fino a 70 HP <i>For car, off the road, tractor tyres. 4 cm piston stroke</i> Can be used to detach the tyres of all type of jeeps, 4x4, cars, trucks without anti-breaking edge and tractors up to 70 HP <i>Est utilisé pour décoller les pneus de tout genre de jeeps, 4x4, voitures, camions sans le bord anti rupture et tracteurs jusqu'à 70 HP</i>	5
3080085C	MICRO-LEM SUPER	Adatto per stallonare i pneumatici di tutti i tipi di jeep, fuoristrada, vetture, camion senza bordo anti stallonamento e trattori fino a 70 HP <i>Can be used to detach the tyres of all type of jeeps, 4x4, cars, trucks without anti-breaking edge and tractors up to 70 HP</i> <i>Est utilisé pour décoller les pneus de tout genre de jeeps, 4x4, voitures, camions sans le bord anti rupture et tracteurs jusqu'à 70 HP</i>	5,5
3080085E	MINI-LEM F	Adatto per stallonare il tallone interno ad esempio di tutti i tipi di pneumatici fino a 24": camion, mietitrebbia e trattori fino a 150 HP <i>Can be used to the inside and outside tyre bead of all types of tyres up to 24": trucks, combine-harvesters and tractors up to 150 HP</i> <i>Est utilisé soit à l'intérieur qu'à l'extérieur du talon des pneus de tout genre jusqu'à 24": camions, moissonneuses-batteuses et tracteurs jusqu'à 150 HP</i>	8,7
3080085G	VIKING 2.7 + PUMP	Adatto per staccare principalmente i cerchioni dei camion dal mozzo. Completo di pompa 400 bar. Potenza stallonatura 7000 kg <i>Suitable to remove mainly the rims of trucks from the hub. Delivered with pump 400 bar. Power bead 7000 kg</i> <i>Approprié pour éliminer principalement les jantes de camions du moyeu. Avec pompe 400 bar.</i> <i>Puissance perles 7000 kg</i>	1,5 + 4,9
3080085L	SATURNIA 25" -35"	Agisce sull'allineamento degli anelli conici ed è adatto per macchine movimento terra da 3 a 5 pezzi da 25" a 35". Facilita il montaggio della guarnizione di tenuta e dell'anello antiestrusione. Tutte le operazioni possono essere svolte da un solo operatore. <i>Conic rings alignment machine for E.M. on 3 and 5 pieces from 25" to 35". Easy assembly of O-Ring and ring stop-seeger. All operations can be performed by an operator only.</i> <i>Outil à l'alignement des anneaux coniques pour les engins de terrassement de 3 à 5 pièces de 25" à 35".</i> <i>Montage facile du joint et de la bague de butée. Toute opération peut être faite par un seul opérateur.</i>	20



3080086M



3080086



3080086C

Codice Code Code	Descrizione Description Description	Note Notes Notes	Peso kg Weight kg Poids kg
3080085M	VOYAGER	<p>Macchina per il montaggio degli anelli conici su cerchioni sia a 3 pezzi che a 5 pezzi da 25" a 35". Facilita il montaggio della guarnizione O-Ring e dell'anello di arresto-seeger. Tutte le operazioni sono eseguibili da un solo operatore. Possibilità di ruotare di 360°, ciò permette di lavorare su qualsiasi punto del cerchio. <i>VOYAGER is a conic rings alignment machine for E.M. on 3 and 5 pieces from 25" to 35". Easy assembly of O-Ring and ring stop-seeger. All operations can be performed by an operator only. Possibility to rotate of 360°, this allows to work on any point of the rim. VOYAGER est un outil à l'alignement des anneaux coniques pour les engins de terrassement de 3 à 5 pièces de 25" à 35". Montage facile du joint et de la bague de butée. Toute opération peut être faite par un seul opérateur. Rotation de 360° qui permet de travailler sur n'importe quel point de la jante.</i></p>	39
3080086	VIKING 4 MAGNETIC	<p>Lavora nella parte interna del cerchio. Si appoggia al telaio della macchina e spinge l'anello del cerchio il quale a sua volta stallonare il pneumatico dalla sua sede. Utilizzato su cerchioni sia a 3 pezzi che a 5 pezzi, di macchine movimento terra che vanno da 25" a 51". In dotazione ha 5 prolunghe (una da 100 mm, due da 50 mm e 2 da 25 mm). <i>Acts on the inner part of the rim. It leans on the chassis of the machine and pushes the ring of the rim which removes the tyre from its seat. Used with rims in three and five pieces, mounted on earth-moving machines from 25" to 51". It is delivered with 5 extensions (one of 100 mm, two of 50 mm each and 2 of 25 mm each) as standard accessories. Utilisé sur l'intérieure de la jante. il appuie sur la châssis de la machine et pousse la bague de la jante qui enlève le pneu de son siège. Utilisé sur les jantes de 3 à 5, pièces montées sur les engins de terrassement de 25" à 51". Il est fourni avec 5 allonges (une de 100mm, deux de 50 mm et deux de 25 mm) en tant d'accessoires standards.</i></p>	3
3080086C	SHUTTLE-8 SP	<p>Adatto a stallonare il tallone dei pneumatici con qualunque tipo di cerchioni da 5 pezzi dotati del corretto punto di attacco su ambo i lati, da 25" a 51". Questo tipo di cerchioni è comunemente utilizzato su caterpillar di medie e grandi dimensioni <i>Can be used to detach bead of the tyres of all types of rims in five pieces which have the proper anchoring seat on both sides, from 25" to 51". This type of rims are commonly used on big and medium-sized caterpillars. Est utilisé pour décoller le talon des pneus de tout genre aux jantes à 5 pièces qui ont le bon ancrage des deux côtés de 25" à 51". Ce type de jantes sont communément utilisés sur les grandes et moyennes chenilles.</i></p>	6,8

CONTRASPORTI DI RILASCIAZIONE  
BALANCING WEIGHTS  
VALVOLE E PROLUNGHE  
VALVES AND EXTENSIONS  
COVERLIDS  
COUVERTS  
MONTAGGIO E ACCESSORI  
TYRE MOUNTING AND ACCESSORIES  
OIL COMPRESSOR  
OIL COMPRESSEUR  
PROTEZIONE PNEUMATICO  
TYRE REPAIRING  
SOLLEVAMENTO E ACCESSORI  
LIFTING AND ACCESSORIES  
CURA E MANUTENZIONE  
TYRE CARE AND MAINTENANCE  
ATTREZZI E ACCESSORI  
OTHER EQUIPMENTS AND ACCESSORIES  
TIRES  
TIRES

**STALLONATORI**  
**BEAD BREAKERS**  
**DÉTALONNEURS**



3080086E



3080086F



3080086G

Codice Code	Descrizione Description	Note Notes	Peso kg Weight kg
3080086E	MANTIS HD P	Appositamente creato per stallonare i pneumatici dai cerchioni dei camion, in particolare quelli dotati di bordo anti-stallonamento. Essenziale per cerchi Actros e Alcoa <i>Purposely designed for breaking tyres from rims of trucks, particularly of modern ones with anti bead breaking edge. Needed for Actros and Alcoa rims</i> Spécialement conçu pour détalonner les pneus des jantes des camions, en particulier des camions modernes fournis du bord anti détalonnage. Nécessaire pour Actros et Alcoa jantes	12
3080086F	MAXI LEM SPECIAL MFC	Adatto a stallonare il tallone del pneumatico da entrambi i lati del cerchione di veicoli M.T. che utilizzano cerchioni da 3-5 pezzi fino a 35". <i>Can be used to detach the bead of the tyre on both sides of the rim for E.M. machines which are equipped with pieces rims in 3-5 pieces up to 35".</i> Utilisé pour décoller le talon du pneu des deux côtés de la jante des engins de terrassement avec les jantes de 3 à 5 pièces jusqu'à 35".	13,5
3080086G	MAXI LEM 40T	Studiato appositamente per stallonare il tallone dei pneumatici Mod. 18-0033 da 40 tele montati su gru e porta container (tipo Bellotti, C.V.S., Ferrari, Kalmar, Terex) da ambo i lati del cerchione. <i>Purposely designed for breaking Mod.18-0033 40" crossply tires mounted on cranes and container handling (such as Bellotti, C.V.S., Ferrari, Kalmar, Terex), from both sides of the rim.</i> Spécialement conçu pour décoller les pneus Mod. 18-0033 à 40 crossply (pneus à carcasse diagonale) montés sur les grues en général et surtout sur les grues portuaires (voir Bellotti, C.V.S., Ferrari, Kalmar, Terex) sur les deux côtés de la jante.	13,5



3080086H



3080086P



3080087



3080087B

Codice Code Code	Descrizione Description Description	Note Notes Notes	Peso kg Weight kg Poids kg
3080086H	UNIVERSAL BEAD BREAKER	Stallonatore pneumatico universale per pneumatici tubeless camion, trattore, OTR. Disegno compatto - non necessita di parti opzionali (solo aria compressa) <i>Universal, pneumatic bead breaker for tubeless truck, tractor and OTR tyres. Compact design - no additional parts needed (only compressed air)</i> <i>Détallonneur pneumatique, universel pour pneus tubeless camion, tracteur, OTR. Dessin compacte - il ne nécessite pas de parties optionnelles (seulement air comprimé)</i>	—
3080086P	CU2	Spessori 2 cm con sistema "antiscivolo" per tenere spostato il tallone del pneumatico durante la fase di stallonamento <i>Wedges 2 cm with "antislip" system so that the bead may be moved from the tire during the breaking</i> <i>Câles 2 cm avec système "antidérapant" afin que le talon reste loin du pneu lors du détalonnage</i>	—
3080086R	CU4	Spessori 4 cm con sistema "antiscivolo" per tenere spostato il tallone del pneumatico durante la fase di stallonamento <i>Wedges 4cm with "antislip" system so that the bead may be moved from the tire during the breaking</i> <i>Câles 4 cm avec système "antidérapant" afin que le talon reste loin du pneu lors du détalonnage</i>	—
3080087	HYDRO -PNEUMATIC PUMP	Pompa pneumo-idraulica a pedale 700 bar, pressione aria di lavoro minima 8 bar. Con tubo flessibile di 3 m ed innesto rapido <i>Hydro-pneumatic pump 700 bar, minimum inlet air pressure 8 bar. With flexible hose 3 m long and quick connector.</i> <i>Pompe hydro-pneumatique 700 bar, la pression minimum d'entrée 8 bar. Avec tuyau flexible à 3 m et raccord rapide</i>	—
3080087B	PNEUMATIC PUMP	Pompa idraulica manuale con pedale - 700 bar in uscita. Con tubo flessibile di 3 m ed innesto rapido <i>Manual pedal hydraulic pump - outlet 700 bar. With flexible hose 3 m long and quick connector</i> <i>Pompe hydraulique manuelle à pédale - sortie 700 bar. Avec tuyau flexible à 3 m et raccord rapide</i>	—

CONTRAPRESSORI PER INCAICCIATURA BEADING WEIGHTS  
 VALVOLE PER PNEUMATICI VALVES AND REGULATOR  
 CONFECCIO DI PIASTRE PLATING  
 CONFECCIO DI MANTELLO PER WHEELS AND DISKS  
 OILI COMPRESSI COMPRESSED AIR  
 PNEUMATICI PER PNEUMATICI PNEUMATIC  
 SOLLEVATORI E ACCESSORI LIFTING AND ACCESSORIES  
 CURE E MANUTENZIONE TYRE CARE AND MAINTENANCE  
 ATTREZZI PER ACCESSORI OTHER EQUIPMENT AND ACCESSORIES  
 TRAPE TRAPS